

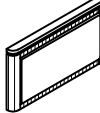

# ASSEMBLY INSTRUCTION FOR ACME FURNITURE

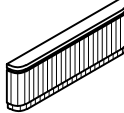

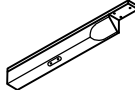

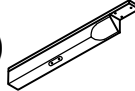

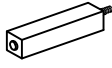
## MODEL # BD04881EK1 / BD04881EK2 / BD04881EK3

Thank you for purchasing the quality product. Be sure to check all packing material carefully for small parts which may have come loose inside the carton during shipment. Separate, identify and count all parts and metal hardware. Compare with all parts list to be sure all parts are present. If any part(s) are missing or damaged, please contact your local furniture dealer. For efficient and speedy service, please indicate the model number and code letter of parts(s) needed.

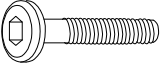
\*\*\*Do not fully tighten screws until fully assembled\*\*\*

COMPONENT PARTS		
DESCRIPTION	PART NAME	Q'TY(PCS)
(A)	HEADBOARD 	1
(B)	FOOTBOARD 	1
(C)	HEADBOARD LEG (LEFT) 	1
(D)	HEADBOARD LEG (RIGHT) 	1
(E)	SIDE RAIL 	2
(F)	BED SLAT 	4
(G)	BED SLAT SUPPORT 	8

## HARDWARE REQUIRED ( BOX OF HEADBOARD)

- ①  BOLT M6 x 40mm - 6 PCS
- ②  SPRING WASHER 1 /4" - 6 PCS
- ③  FLAT WASHER 1 /4" - 6 PCS
- ④  FLATHEAD CHIPBOARD SCREW - 8 PCS  
M4 xx 32mm
- ⑤  ALLEN KEY M4 - 1 PC
- ⑥  ALLEN KEY M5 - 1PC

### Attention:

\*\*\*Some number parts listed in the instruction sheet may not be in parts bags as they already be assembled.  
Carefully check parts and packing materials prior to ordering replacements.

### **How to assemble :**

#### Step 1:

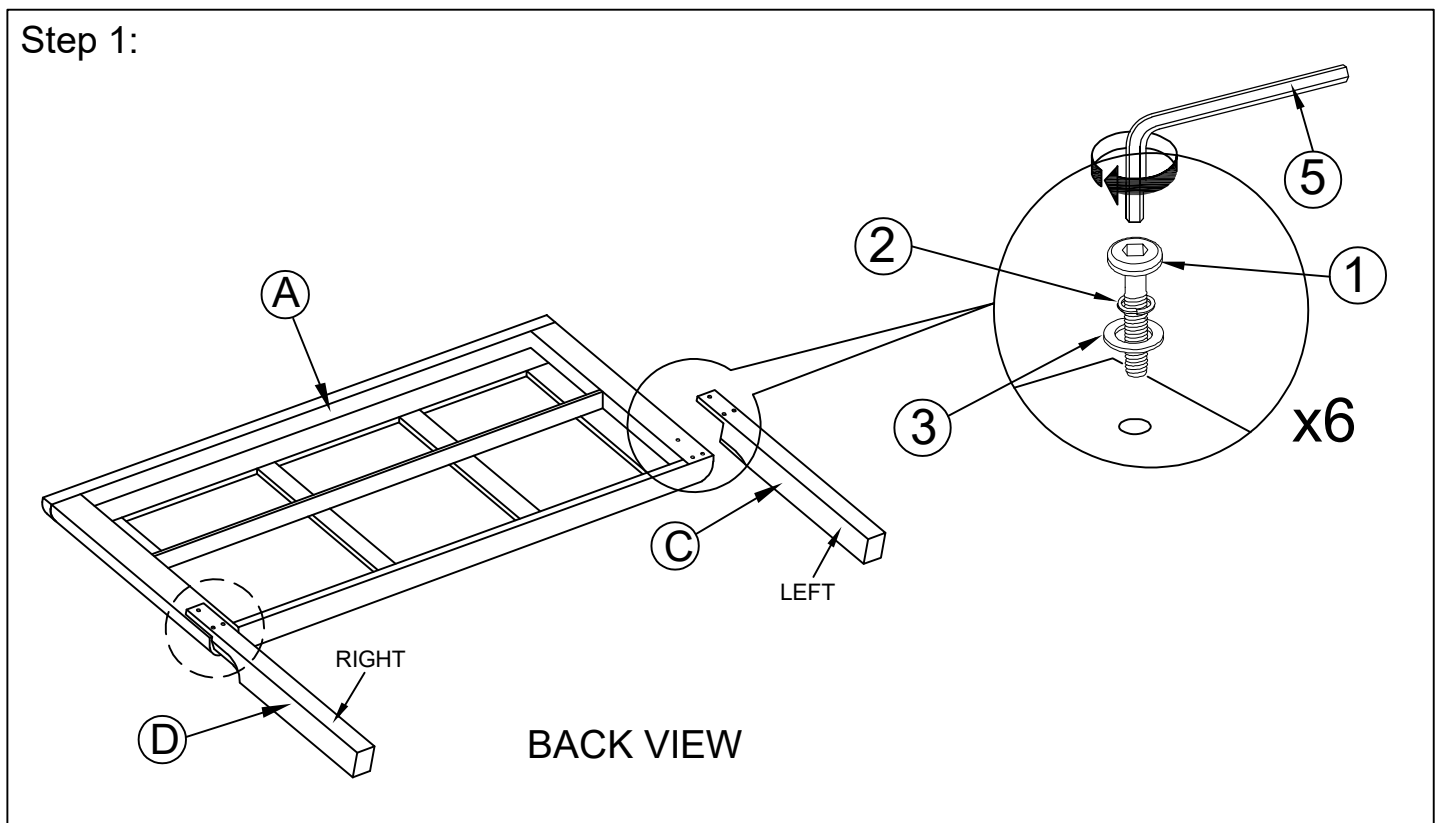

# How to assemble :

Step 2:

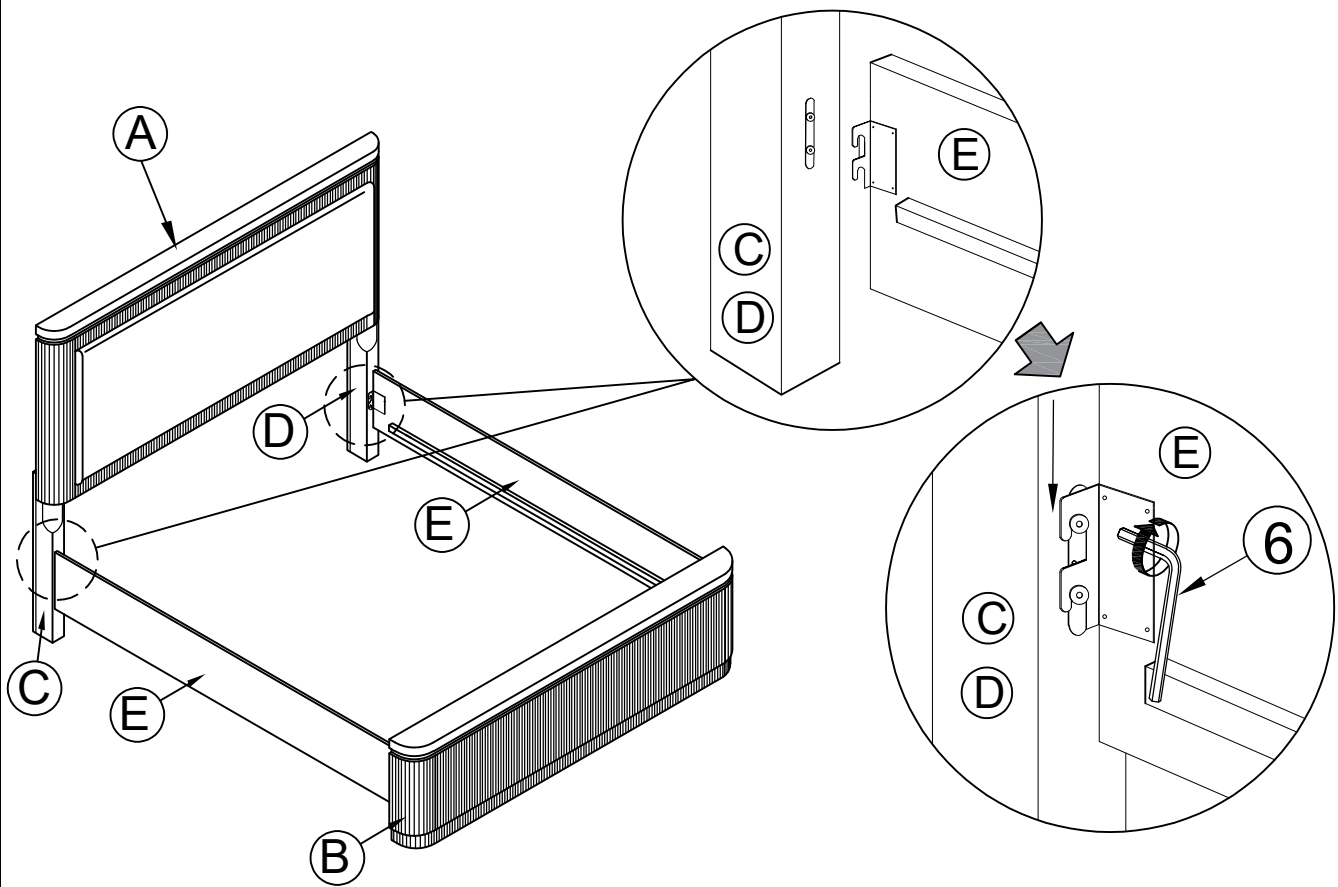

Step 3:

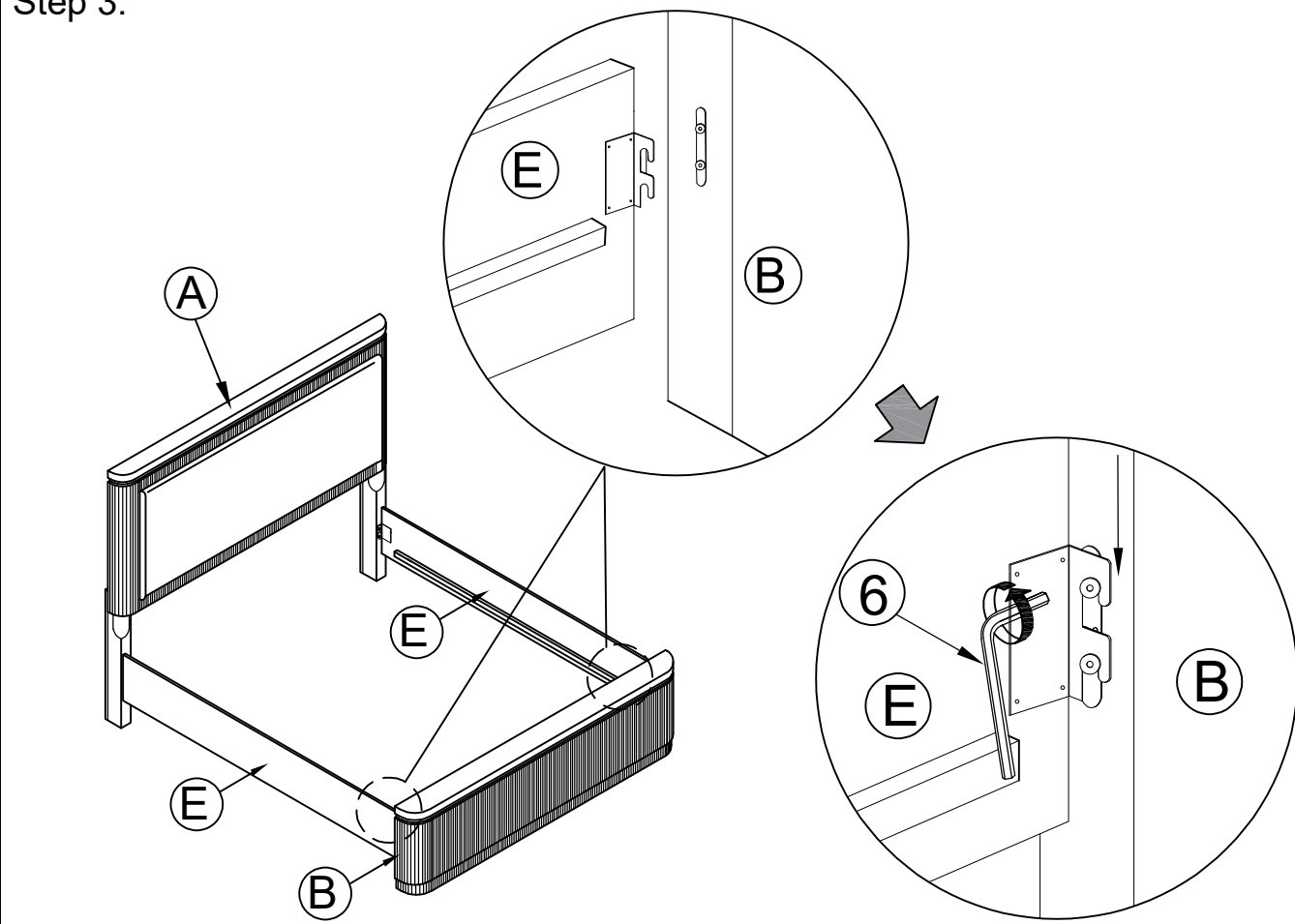

# How to assemble :

Step 4:

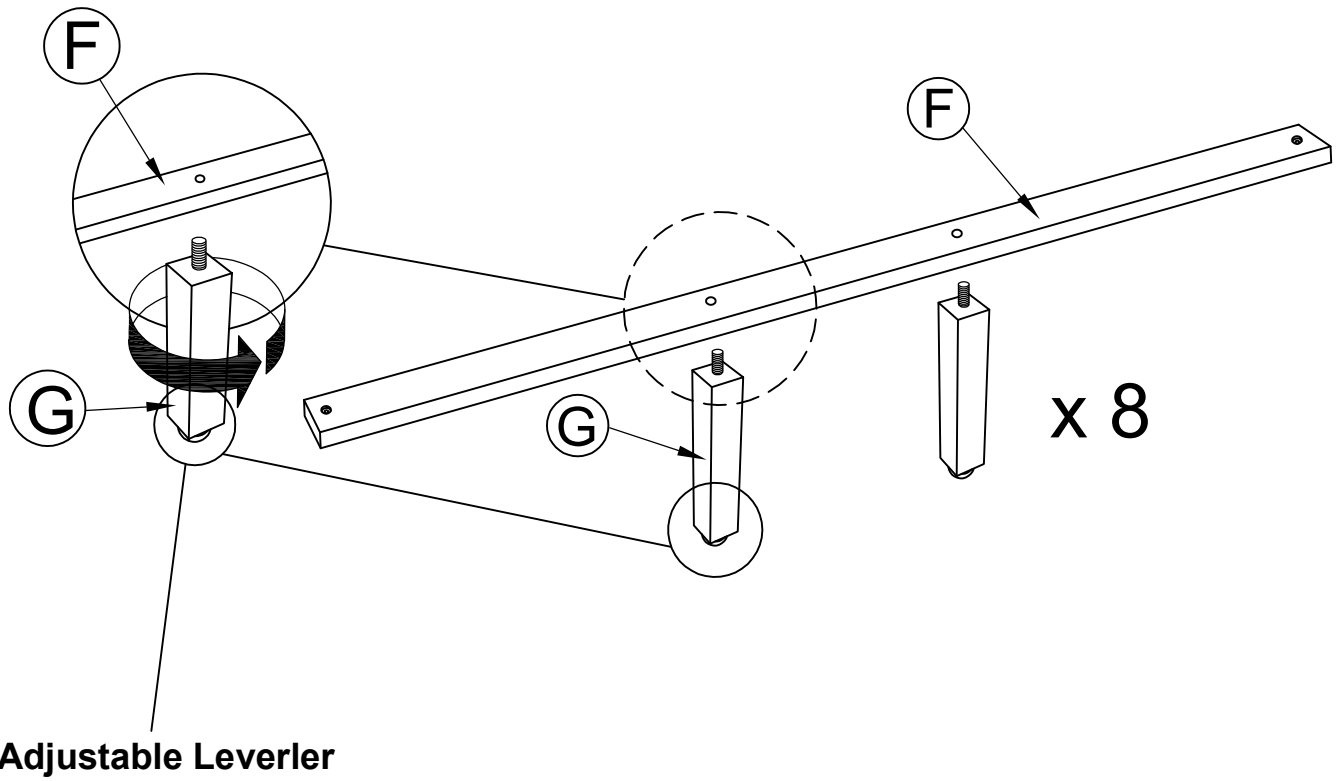

Step 5:  
COMPLETE

